

## Tinplate and Tin Free Steel

镀锡板  
镀铬板

[www.baosteel.com](http://www.baosteel.com)



# Contents 目 录

简 介	Introduction
产品列表	List of Tin Mill Products
产品特性	Features
产品用途	Applications of Tinplate and TFS
制造工艺	Manufacturing Process
供货规格	Available Specifications and Sizes
使用提示	Usage Precautions
订货须知	Information Required with Orders and Inquiries



# Introduction

## 简介



镀锡产品包括电镀锡板、电镀铬板和原板。镀锡板在钢板表面电镀一层金属锡，镀铬板在带钢表面经电镀形成金属铬层和氧化铬层，均具有非常漂亮的金属光泽，优异的耐性蚀和涂饰性。

宝钢股份是中国最大的镀锡产品制造商，拥有先进的工艺装备、丰富的生产管理经验和良好的服务以及一流的产品研发队伍，具备从冶炼、热轧、冷轧到涂镀全流程的制造能力，产品覆盖电镀锡板和电镀铬板，年产量超过120万吨。宝钢是国内唯一能够制造二次冷轧材系列（DR）和DI材镀锡产品的专业厂商，生产的镀锡K-板在国内处于领先水平。宝钢镀锡产品在全球销售，广泛应用于食品、饮料和工业品的包装，在业界享有良好的信誉和知名度。

Tin mill products include electrolytic tinplate, electrolytic chromium coated steel (also referred to as tin free steel or TFS), and black plate, the uncoated steel. Tinplate is a thin steel sheet coated by tin, while TFS is an electrolytic chrome plated steel consisting of a thin layer of chromium and a layer of chromium oxide deposited on the steel base. Both of them have a beautiful, metallic luster as well as excellent properties in corrosion resistance and paintability.

Baosteel is the largest manufacturer of tin mill products in China with advanced technical equipments, first class inspection devices, skilled operators, excellent services and outstanding product development personnel. It possesses integrated process lines including ironmaking, steelmaking, hot rolling, cold rolling and coating. The product catalogue covers ETP and TFS with an annual output of 1.2 million tons. Baosteel is the ONLY professional DR & DI tinplate producer in China, and is the LEADER among domestic K-tinplate producers. Baosteel's tin mill products are widely sold and used throughout the world in application of packaging of food, beverage and industrial goods and enjoy high reputation in the global market.



# List of Tin Mill Products

## 产品系列

### 镀锡产品

### Tin Mill Products

镀锡板 Tinplate Products	一次冷轧镀锡板 (SR ETP)
	二次冷轧镀锡板 (DR ETP)
镀铬板 TFS Products	一次冷轧镀铬板 (SR TFS)
	二次冷轧镀铬板 (DR TFS)

注：  
镀锡板包括K-板、DI材、低锡铁、低铬铁等。

Note:  
Tinplate includes K-tinplate, DI-tinplate, Low-Tin Plate, L-Cr-Tinplate.

### 镀层结构

### Coating Structure

#### 电镀锡产品 ETP Products

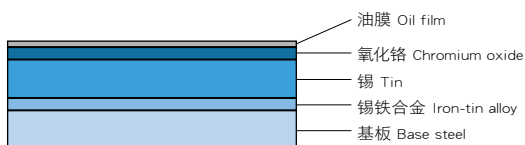

#### 电镀铬产品 TFS Products

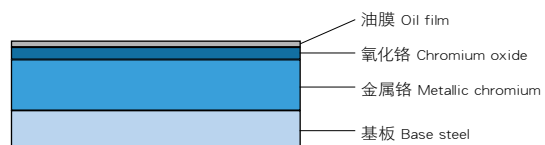



# Features

## 产品特性

### 镀锡板特性

### Features of Tinplate Products

优异的耐腐蚀性	选择合适的镀层厚度，可以满足不同内容物的耐腐蚀性要求
优异的涂饰性	可用各种涂料和油墨进行印刷
优异的焊接性	可用焊接（包括钎焊）制造各式各样的罐头
优异的加工性和强度	选择合适的调质度等级，可以满足加工要求以及成型后的强度
亮丽的外观	镀锡板表面金属光泽亮丽，选择不同表面状态的基板得到不同表面粗糙度的产品

Excellent Corrosion Resistance	By selecting a proper coating weight, appropriate corrosion resistance is obtained against container contents.
Excellent Paintability & Printability	Printing is beautifully finished using various lacquers and inks.
Excellent Solderability & Weldability	TIN PLATE is widely used for making various types of cans by soldering or welding.
Excellent Formability & Strength	By selecting a proper temper grade, appropriate formability is obtained for various applications as well as the required strength after forming.
Beautiful Appearance	Electrolytic ETP is characterized by its beautiful metallic luster. Products with various kinds of surface roughness are produced by selecting the surface finish of the substrate steel sheet.

## 镀铬板特性

### Features of TFS Products

优异的涂料附着力	涂料附着力远远超过镀锡板，可以用于制造 DRD 罐和胶接罐
优异的耐热变性	耐高温烘烤，不变色，材料性能不劣化
优异的抗硫化性	金属铬层有良好的抗硫化物性能，适用于富含蛋白质食物如鱼的听头
优异的耐丝状腐蚀性	漆膜下的耐丝状腐蚀能力优异
优异的耐碱性	镀铬层是非两性材料，更适用于碱性内容物如清洁剂、颜料分散剂的包装

Excellent paint adhesion	TFS has excellent paint adhesion properties that far surpass those of ETP, allowing its use for making DRD cans and adhesive bonded cans.
Excellent heat resistance	High-temperature baking causes neither discoloration nor deterioration in material properties.
Excellent resistance to Sulphur Blackening	The metallic chromium in TFS has excellent sulphide resistance property when canning protein-rich foodstuff such as fish. TFS compensates for the expensive sulphur resistant lacquer.
Excellent filiform rust resistance	TFS has a excellent under film corrosion resistance.
Excellent alkali resistance	The coating in TFS is not amphoteric. Alkaline products such as detergents and dispersion colours can be packed in TFS with advantage.



## TFS 和 ETP 不同特性

### Different Features between TFS and ETP

外观	即使使用相同表面状态的原板，TFS 的表面外观与 ETP 不同，呈现其独特的金属铬光泽。
耐蚀性	印涂后的 TFS 具有优良的耐蚀性，因此通常是两面印涂；但依据内容物种类也可以采用罐内表面素铁。
钎焊性	TFS 不能钎焊。
焊接性	即使去除金属镀铬层 TFS 可焊接，但焊接性差于镀锡板。
镀层重量	镀铬板一般仅有一种镀层厚度产品，而镀锡板有一系列的厚度标准。

Appearance	Even when the same surface finish as ETP is applied to the substrate steel sheet, it provides the unique surface luster characteristic of metallic chromium.
Corrosion resistance	As it has excellent corrosion resistance after painting, it is generally used with both surfaces painted. It can also be used with the internal surface unpainted, depending on the contents.
Solderability	TFS is not compatible with soldering.
Weldability	Although TFS can be welded when the metallic coating layers are removed, its weldability is inferior to ETP.
Coating weights	Unlike the multiplicity of coating weights with tin, only one standardized chromium-coated product is manufactured.



性能对照表  
Comparison of Properties

		镀锡板 Tinplate		镀铬板 TFS
		2.8	Over 5.6	
素材耐蚀性（密封） Bare Corrosion Resistance (sealed) <sup>(1)</sup>	防锈能力 Rust Resistance	○	◎	○
	耐酸性 Acid Resistance	○	○	△
	耐碱性 Alkali Resistance	△	△	◎
	抗硫化黑斑 Black Sulfide Stain Resistance	△	△	◎
	抗应力开裂能力 Stress Cracking Resistance	◎	◎	○
	涂装性 Paintability	○	○	◎
涂装后耐蚀性 Corrosion Resistance after Painting <sup>(2)</sup>	◎	◎	○	
抗丝状腐蚀性 Filiform Corrosion Resistance	◎	◎	◎	
涂料附着力 Paint Adhesion	○	○	◎	
加工性 Formability	◎	◎	○	
钎焊性 Solderability	○	◎	X	
焊接性 Weldability	○	○	△ <sup>(3)</sup>	
耐热变性 <sup>(4)</sup> Heat Resistance <sup>(4)</sup>	○	○	◎	

◎: 优 excellent    ○: 良 good    △: 好 fair    X: 差 poor

注:

- (1) 素材耐蚀性测试应在完全密闭环境进行。
- (2) 划线腐蚀测试用于评估涂装后的耐蚀性。
- (3) 焊接性测试时, 未研磨去除金属镀层。
- (4) 涂装或者印涂后的高温烘烤可能改变材料性能。

Note:

- (1) Bare corrosion resistance is evaluated under tightly sealed conditions.
- (2) Corrosion resistance after painting is evaluated by crosshatching corrosion tests.
- (3) The evaluation is for the case where welding is performed without grinding the surface to remove the metallic coating layer.
- (4) High-temperature baking after painting and printing may cause changes in material properties.



## 镀锡板食品罐的优点

### Advantages of Tinplate Cans in Food Packaging

卫生 Hygienic	提供优异且无毒的屏障保护食品，保持水份，不受污染，保持食品风味。 Provide excellent and non-toxic barrier properties to protect food products from impurities, bacteria, moisture, light, and odours.
安全 Safe	轻质和高强度的食品罐便于运输和储存。 Low weight and high strength make food cans easy to ship and store.
生态友好 Eco-friendly	可 100% 回收，比铝的成本低。 Offer 100% recyclability; and significant cost benefits compared with aluminum.

## 镀锡 K- 板耐蚀能力

### K-Tinplate's Resistance to Corrosion

酸浸时滞值 PLV Pickling Lag Value	铁溶出值 ISV Iron Solution Value	锡晶粒度 TCS Tin Crystallite Size	合金 - 锡电偶合 ATC Alloy-Tin Couple
≤ 10 Sec	≤ 20 μ g/3in <sup>2</sup>	≤ 9#	≤ 0.12 μ A/3in <sup>2</sup>

注：  
差厚镀锡板检测厚镀层面板的性能。

Note:  
If different coating tinplate, the side of higher coating weight was tested.

## DR 材镀锡产品机械性能

### Mechanical Properties of DR Tin Mill Products

调质度代号 Temper Grade	硬度 (HR30Tm) Hardness		屈服强度目标 Yield Strength/ MPa
	目标值 Target Value	范围 Range	
DR-7M	71	71 ± 5	520
DR-8	73	73 ± 5	550
DR-8M	73	73 ± 5	580
DR-9	76	76 ± 5	620
DR-9M	77	77 ± 5	660
DR-10	80	80 ± 5	690

注：  
使用DR板时，必须保持罐身成圆方向与板材的轧制方向一致。

Note:  
Making cans with DR materials, please pay a special attention to the rolling direction.



# Applications of Tinplate and TFS

## 产品用途

### 消费品、工业品的包装

#### Consumer Packaging and Industrial Packaging

镀锡板  
TINPLATE

镀主要用于包装食品、饮料的罐头，也用于包装汽油、油脂、颜料、抛光剂、喷雾剂等化学品的容器，包括盖子和罐身。

ETP is primarily used for packaging foodstuffs and beverages, but it is also used in containers for oils, grease, paints, polishes, chemicals and many other products. Aerosol containers and caps and closures are also made from ETP.

镀铬板  
TFS

主要用作罐头顶盖，旋开盖、凸盖、易拉盖、浅冲罐。

TFS are most frequently used for can tops, screw and lug caps, snap and press-on closures and shallow-drawn food cans.

### 其他用途

#### Miscellaneous

电子方面  
in Electronics

电极、电缆带、电磁屏幕罩壳等  
Electrodes, Cable tape, Magnetic screen covers, etc.

工程方面  
in Engineering

汽车滤油器、汽车空滤、垫片等  
Automotive oil filters, Automotive air filters, Gaskets, etc.

建筑方面  
in Construction

气体流量计内部件、热交换器、厨具、货架等  
Gas meter internal components, Heat exchangers, cookware, shelving, etc.



## 宝钢产品应用实绩 Application Examples



### DI罐

钢制二片易拉罐, 代表着镀锡板生产的最高水平, 目前宝钢DI材已大量用于cocacola、peisi-cola等的包装。

### DI can

Two-piece steel can represents the highest development level of tinplate production. Nowadays, Baosteel's DI material is used for two-piece can to pack beer and carbonated beverage such as Cocacola and Pepsi-cola.

### 三片饮料罐

代表用户有王老吉、红牛、娃哈哈等品牌的包装。

### Three-piece can for beverage

Representative clients: include Wanglaoji, Redbull, Robust, etc.

### 食品罐（三片罐和二片罐）

宝钢镀锡板已广泛应用于食品包装的各个领域, 包括水果罐头、肉类罐头、鱼罐头、蔬菜罐头等。代表用户有黄罐、梅林、古龙等。

### Food can (3-piece can & 2-piece can)

Baosteel's tin mill products are used for the package of all kinds of canned food such as Huangguan, Meilin and Gulong.

## Applications of Tinplate and TFS 产品用途



### 旋开盖、皇冠盖、易开盖

宝钢镀锡板已广泛地应用于百威、哈啤、燕京等知名品牌，是无锡华鹏、紫泉集团、义乌易开盖等制盖企业的主供应商。



### Metal closure and ends

Baosteel's tinplate and TFS are used for Budweiser, Harbin and Yanjing beer, etc. Baosteel's the major supplier of Ziquan Group, Huapeng closures, Yiwu Easy Open End Industry Group, etc.



### 喷雾罐

目前代表用户有杭州美特、深圳华特、中山凯达等。



### Spray can

Clients are Hangzhou Meite, Shenzhen Huate, zhongshan Kaida, etc.

### 高档化工罐

目前宝钢镀锡产品已用于立邦、国际油漆、司马等知名品牌的包装。

### 高档礼品罐

宝钢镀锡产品大量应用于礼品包装，多为异形罐。



### High-grade industrial package

Tinplate and TFS are used for the package of Nippon, International Paint, Sigma.

### High-grade gift package

Irregular cans are made from Baosteel's tinplate and TFS for high-grade gift package.



# Manufacturing Process

## 制造工艺

生产流程示意图  
Process Diagram

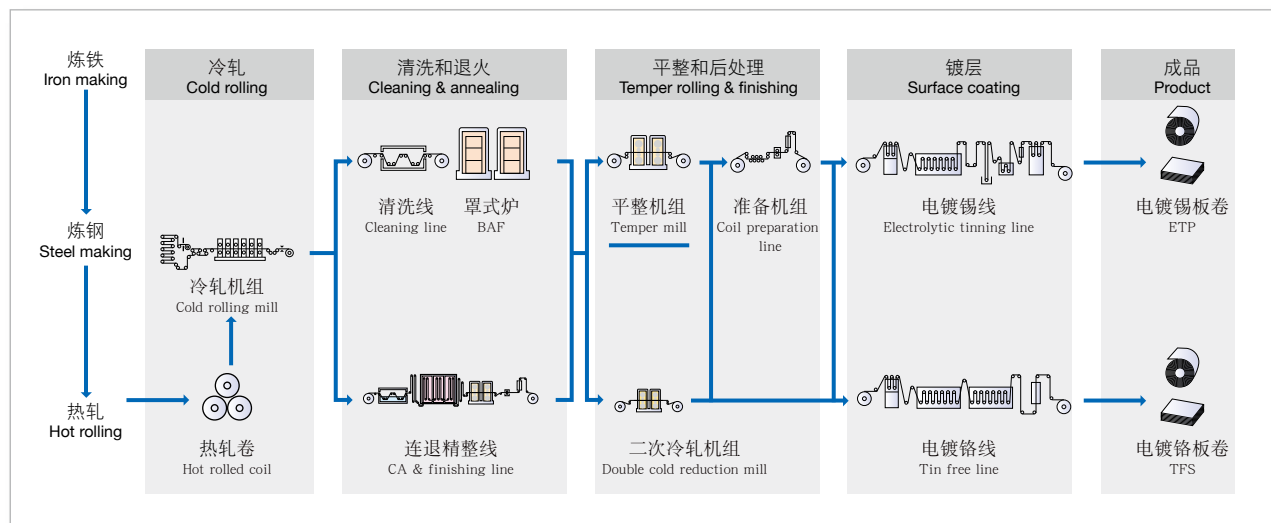

注：  
镀锡板和镀铬板在全工序制造流程中严格遵守宝钢“一贯制”质量管理的要求，因此保证了优异的耐蚀性和均匀的材料性能满足制罐材料要求。

Note:  
Tinplate and TFS products are manufactured under strict quality control all through the manufacturing process to provide the excellent corrosion resistance and uniform material properties required of can-making materials.



### 主要制造工序的重要管理项目

#### Major Control Items in the Manufacturing Process

炼 钢 Steelmaking	化学成份、夹杂	Steelmaking: Chemical composition, minimization of inclusions.
热 轧 Hot Rolling	终轧温度、卷取温度、厚度曲线	Finishing temperature, coiling temperature, gage profile.
冷 轧 Cold Rolling	厚度、板形	Gage, flatness.
退 火 Annealing	退火温度、均热温度、冷却温度、退火气氛	Heating temperature, soaking temperature, cooling temperature, atmospheric gas composition.
平 整 Temper Rolling	板形、表面粗糙度	Shape, surface roughness.
电 镀 Electrolytic Plating	镀层厚度、化学处理、涂油量	Coating weight, chemical treatment, oiling amount.

### 镀锡产品检测参数

#### ETP and TFS's Parameters Inspected

A	机械性能 Mechanical Properties	硬度 (调质度)	Hardness (temper grade)
B	尺寸精度 Dimensional Accuracy	厚度 宽度 剪切长度	Thickness Width Cut-length
C	板形参数 Shape Parameters	翘曲 镰刀弯 不平度 边浪	Bowness Camber Askewness Edge waviness
D	润滑 Lubrication	油膜厚度	Oil film
E	耐腐蚀性 Corrosion Resistant Property	锡层 (镀锡板) 金属铬和氧化铬 (TFS) 钝化层厚度 合金 - 锡电偶合 (需要时) 铁溶出值 (需要时) 锡晶粒度 (需要时) 抗硫化性 (需要时) 孔隙率 (需要时) 酸浸时滞 (需要时)	Tin coating (for Tinplate) Metallic chromium and chromium in Cr-oxide (for TFS) Passivation film weight Alloy-tin Couple (for required) Iron solution value (for required) Tin grain size (for required) Corrosion resistance SO <sub>2</sub> test (for required) Porosity Test (for required) Pickling lag value (for required)



# Available Specifications and Sizes

## 供货规格

### 钢 种

#### Steel Types

钢种 Steel grade	特 性 Characteristics	适用产品 Products
MR	非金属夹杂物含量与 L 类钢相近，残余元素含量的限制没有 L 类钢严格，具有良好的耐蚀性，适用于大多数用途。 Base steel low in residual elements that has excellent corrosion resistance, widely used in general applications.	ETP、TFS
L	非金属夹杂物以及 Cu、Ni、Cr、Mo 等残余元素含量低，用于对耐蚀性有较高要求的用途。 Base steel extremely low in residual elements such as Cu, Ni, Co, and Mo that has excellent corrosion resistance to certain types of food products.	ETP、TFS
D	用于深冲压或限制滑移线产生的用途。 Aluminum-killed base steel used in applications involving deep drawing or other types of severe forming that tend to give rise to Lueder's lines.	ETP

注：  
若需要特殊钢种，请联系我们。

Note:  
With regard to steel types other than those listed above, please consult us.



## 尺寸规格

### Available Sizes

#### 1. 镀锡板 ETP

基板类型 Black Plate	公称厚度 Normal Thickness	公称宽度 Normal Width	公称长度 (钢板) Normal Length (sheet)
一次冷轧 Single Reduce	0.17 ~ 0.55mm	700 ~ 1200mm	500 ~ 1168mm
二次冷轧 Double Reduce	0.12 ~ 0.36mm		

#### 2. 镀铬板 TFS

基板类型 Black Plate	公称厚度 Normal Thickness	公称宽度 Normal Width	公称长度 (钢板) Normal Length (sheet)
一次冷轧 Single Reduce	0.17 ~ 0.55mm	700 ~ 1050mm	500 ~ 1168mm
二次冷轧 Double Reduce	0.12 ~ 0.36mm		

## 调质度

### Temper Grade

基板类型 Black Plate	罩式退火 Box Annealing	连续退火 Continuous Annealing
一次冷轧 Single Reduce	T-1, T-2, T-2.5, T-3	T-1.5, T-2.5, T-3, T-3.5, T-4, T-5
二次冷轧 Double Reduce	DR-7M, DR-8, DR-8M, DR-9, DR-9M, DR-10	

注:

- (1) 提供两种退火方式: 罩式退火 (BA) 或者连续退火 (CA), 如果为连续退火, 调质度表示为 T-4CA。
- (2) 二次冷轧材 (DR材) 也提供罩式退火, 公称宽度范围为: 700-1050mm。

Note:

- (1) There are two types of annealing: batch annealing (BA) and continuous annealing (CA). When continuous annealing is designated, the symbol of "CA" is added after the temper grade symbol such as "T-4CA".
- (2) The DR materials can also be manufactured by box annealing. Normal Width limited from 700~1050mm. Please consult us.



## 镀层厚度 Coating Weight

### 1. 镀锡板 ETP

	原镀锡量代号 Former Coating Designation	镀锡量代号 Coating Weight Code	公称镀锡量 Nominal Coating Weight (g/m <sup>2</sup> )	最小平均镀锡量 Minimum average Coating Weight (g/m <sup>2</sup> )
等厚镀锡 Equally Coated	10#	1.1/1.1	1.1/1.1	0.9/0.9
	20#	2.2/2.2	2.2/2.2	1.8/1.8
	25#	2.8/2.8	2.8/2.8	2.5/2.5
	50#	5.6/5.6	5.6/5.6	5.2/5.2
	75#	8.4/8.4	8.4/8.4	7.8/7.8
	100#	11.2/11.2	11.2/11.2	10.1/10.1
差厚镀锡 Differentially Coated	25#/10#	2.8/1.1	2.8/1.1	2.5/0.9
	50#/10#	5.6/1.1	5.6/1.1	5.2/0.9
	50#/25#	5.6/2.8	5.6/2.8	5.2/2.5
	75#/25#	8.4/2.8	8.4/2.8	7.8/2.5
	75#/50#	8.4/5.6	8.4/5.6	7.8/5.2
	100#/25#	11.2/2.8	11.2/2.8	10.1/2.5
	100#/50#	11.2/5.6	11.2/5.6	10.1/5.2
	100#/75#	11.2/8.4	11.2/8.4	10.1/7.8
	125#/50#	15.1/5.6	15.1/5.6	13.9/5.2

注:

- (1) 应该按照产品最终用途选择镀锡层厚度: 锡层厚的用于需要高耐蚀性或者素板的场合; 锡层薄的用于耐蚀性要求不高或者印涂之后使用的场合。
- (2) 差厚镀层产品使用差厚标识线沿板的边缘进行标识, 以示区别。
- (3) 有关标识的其他要求, 请向我们咨询。

Note:

- (1) The tin coating weight is determined in accordance with specific end use applications. Tinplate with a heavy coating weight is used for making cans that require a high corrosion resistance or those used bare. Tinplate with a light coating weight is used for making cans that do not require so high a corrosion resistance or those used after painting or printing.
- (2) Differential Markings A white line (differential marking) is painted along the edge of a differentially coated product in order to clearly indicate that it is differentially coated.
- (3) With regard to other types of differential markings, please consult us.

## 2. 镀铬板 TFS

金属铬镀层 (每面) Metallic Chromium Layer (one side)		氧化物铬层 (每面) Chromium Oxide Layer (one side)	
最小平均重量 Minimum Average Coating Weight	最大平均重量 Maximum Average Coating Weight	最小平均重量 Minimum Average Coating Weight	最大平均重量 Maximum Average Coating Weight
50 mg/m <sup>2</sup>	150 mg/m <sup>2</sup>	5 mg/m <sup>2</sup>	35 mg/m <sup>2</sup>

## 表面状态

### Surface Finishes

#### 1. 镀锡板 ETP

原板类型 Black Plate	代号 Code	表面状态 Surface Finish	特征 Characteristics
一次冷轧 Single Reduce	B	光亮表面 Bright surface	在具有极细磨石花纹的光滑表面的原板上镀锡后进行锡的软熔处理得到的有光泽的表面。 Glazed surface obtained after melting treatment of electro tinned smooth raw material strip with extremely fine stone figures by processing.
	R	石纹表面 Stone surface	在具有一定方向性的磨石花纹为特征的原板上镀锡后进行锡的软熔处理得到的有光泽的表面。 Glazed surface obtained after melting treatment of electro-tinned raw material strip featuring certain oriented stone figures.
	R2	粗石纹表面 Stone rough surface	在具有一定方向性的磨石花纹为特征的原板上镀锡后进行锡的软熔处理得到的有光泽的表面, 其表面粗糙度略高于石纹表面。 Glazed surface obtained after melting treatment of electro-tinned raw material strip featuring certain oriented stone figures, roughness higher than "R".
	S	银色表面 Silver surface	在具有粗糙无光泽表面的原板上镀锡后进行锡的软熔处理得到的有光泽的表面。 Glazed surface obtained after melting treatment of electro-tinned raw material strip with rough matt surface.
	S2	粗银色表面 Silver rough surface	在具有粗糙无光泽表面的原板上镀锡后进行锡的软熔处理得到的有光泽的表面, 其表面粗糙度略高于银色表面。 Glazed surface obtained after melting treatment of electro-tinned raw material strip with rough matt surface, roughness higher than "S".
	M	无光表面 Matte surface	在具有一般无光泽表面的原板上镀锡后不进行锡的软熔处理的无光表面。 Matt surface of general matt raw material strip without reflowing treatment.
二次冷轧 Double Reduce	R	石纹表面 Stone surface	在具有一定方向性的磨石花纹为特征的原板上镀锡后进行锡的软熔处理得到的有光泽的表面。 Glazed surface obtained after melting treatment of electro-tinned raw material strip featuring certain oriented stone figures.
	M	无光表面 Matte surface	在具有一般无光泽表面的原板上镀锡后不进行锡的软熔处理的无光泽表面。 Matt surface of general matt raw material strip without reflowing treatment.

## 2. 镀铬板 TFS

原板类型 Black Plate	代号 Code	表面状态 Surface Finish	特 征 Characteristics
一次冷轧 Single Reduce	B	光亮表面 Bright surface	在具有磨石花纹的光滑表面的原板上镀铬后得到的有光表面。 Glazed surface obtained by a thin layer of chromium and chromium oxide deposited on the smooth steel base with extremely fine stone figures by processing.
	R	石纹表面 Stone surface	在具有一定方向的磨石花纹表面的原板上镀铬后得到的有光表面。 Glazed surface obtained after a thin layer of chromium and chromium oxide deposited on the smooth steel base featuring certain oriented stone figures.
	R2	粗石纹表面 Stone rough surface	在具有一定方向的磨石花纹表面的原板上镀铬后得到的有光表面，表面粗糙度略高于石纹表面。 Glazed surface obtained after a thin layer of chromium and chromium oxide deposited on the smooth steel base featuring certain oriented stone figures, roughness higher than "R".
	M	无光表面 Matte surface	表面无光泽。 Matt surface.
二次冷轧 Double Reduce	R	石纹表面 Stone surface	在具有一定方向的磨石花纹表面的原板上镀铬后得到的有光表面。 Glazed surface obtained after a thin layer of chromium and chromium oxide deposited on the smooth steel base featuring certain oriented stone figures.

## 涂油

### Oiling

无特殊要求, 表面涂DOS油, 且采用静电涂油方式。

If no engagement, tinplate and TFS are electro statically oiled with DOS.



## 包装和标识 Packaging and Marking

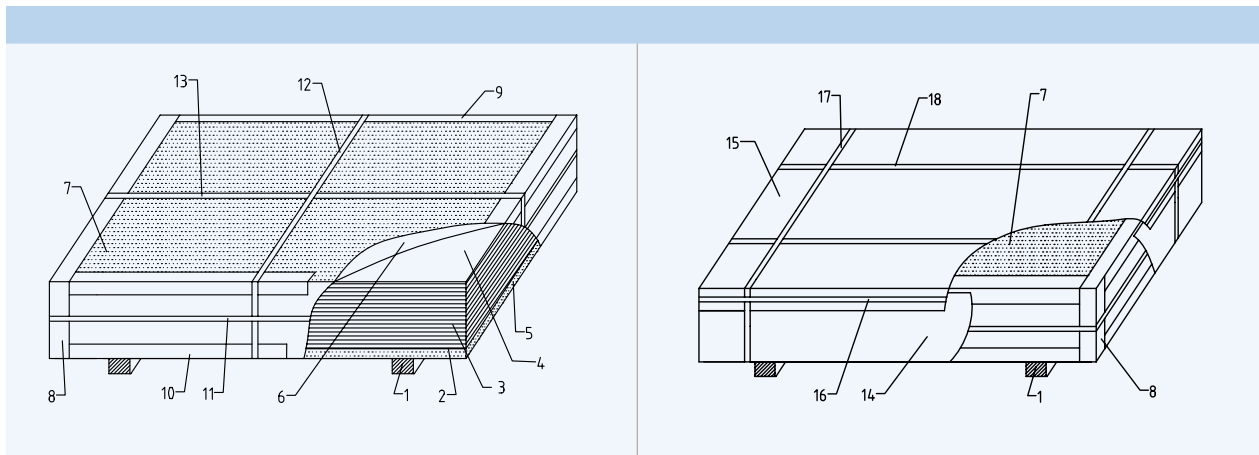

- 1. 木台;
- 2. 下盖板;
- 3. 钢板;
- 4. 上盖板;
- 5. 底部瓦楞纸;
- 6. 防锈纸;
- 7. 上部瓦楞纸;
- 8. 边部护角;
- 9. 上部护角;
- 10. 下部护角;
- 11. 周向捆带 (内);
- 12. 横向捆带 (内);
- 13. 纵向捆带 (内);
- 14. 围板;
- 15. 盒盖;
- 16. 周向捆带 (外);
- 17. 横向捆带 (外);
- 18. 纵向捆带 (外)

- 1. wood bracket;
- 2. bottom cover;
- 3. steel sheet
- 4. top cover;
- 5. bottom corrugated paper;
- 6. rust-proof paper;
- 7. top corrugated paper;
- 8. side corner guard;
- 9. top corner guard;
- 10. bottom corner guard;
- 11. circumferential banding strip (inner);
- 12. horizontal banding strip (inner);
- 13. vertical banding strip (inner);
- 14. guard plate;
- 15. steel package box;
- 16. circumferential banding strip (outer);
- 17. horizontal banding strip (outer);
- 18. vertical banding strip (outer)



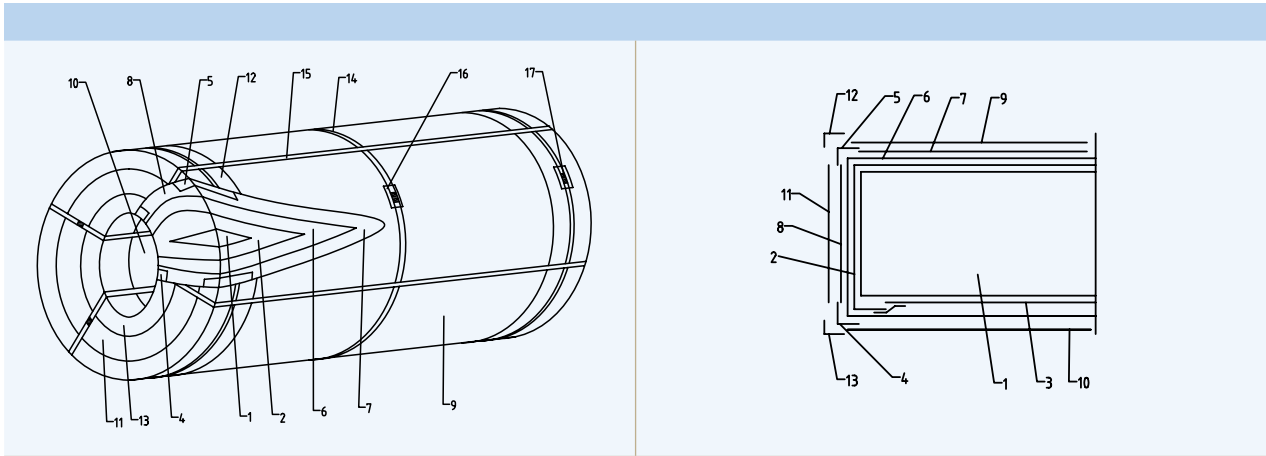

- |               |           |
|---------------|-----------|
| 1. 钢卷;        | 10. 内周护板; |
| 2. 外周防锈纸;     | 11. 铁圆护板; |
| 3. 内芯防锈纸;     | 12. 铁外护角; |
| 4. 纸内护角;      | 13. 铁内护角; |
| 5. 纸外护角;      | 14. 周向捆带; |
| 6. 塑料套;       | 15. 径向捆带; |
| 7. 外周瓦楞纸或纤维板; | 16. 锁扣垫片; |
| 8. 圆护瓦楞纸;     | 17. 锁扣    |
| 9. 外周包板;      |           |

- |  |                                    |
|--|------------------------------------|
| 1. steel coil;   | 10. inner peripheral guard plate;  |
| 2. external peripheral rest-proof paper;               | 11. iron round cover;              |
| 3. inner core rest-proof paper;                        | 12. iron external corner guard;    |
| 4. paper inner corner guard;                           | 13. iron inner corner guard;       |
| 5. paper external corner guard;                        | 14. circumferential banding strip; |
| 6. plastic sleeve;                                     | 15. radial banding strip;          |
| 7. external peripheral corrugated paper or fibreboard; | 16. shim for lock;                 |
| 8. round corrugated paper guard;                       | 17. lock                           |
| 9. external peripheral wrapping plate;                 |                                    |

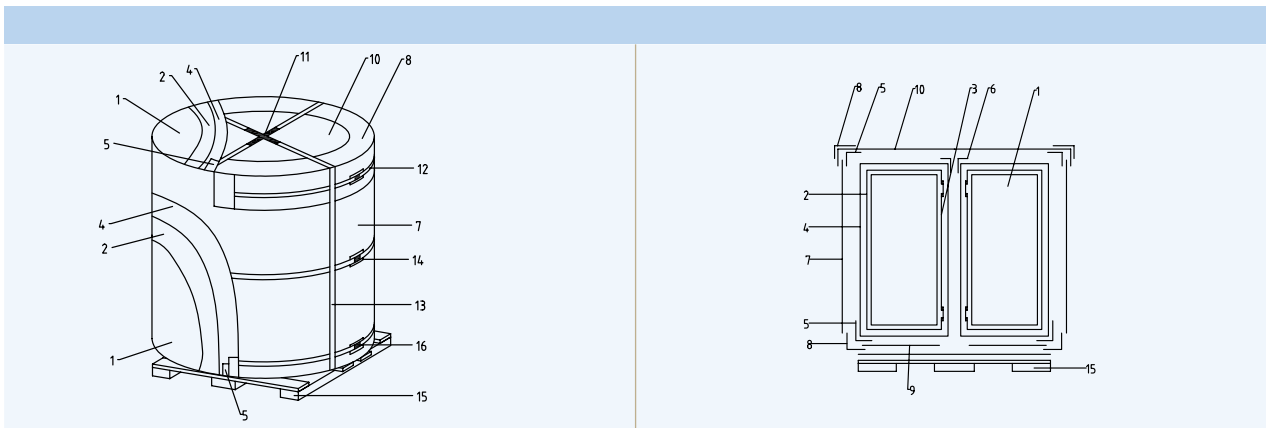

- |           |           |
|-----------|-----------|
| 1. 钢卷;    | 8. 铁外护角;  |
| 2. 外周防锈纸; | 9. 外周包板;  |
| 3. 内芯防锈纸; | 10. 内周护板; |
| 4. 纸内护角;  | 11. 周向捆带; |
| 5. 纸外护角;  | 12. 径向捆带; |
| 6. 铁圆护板;  | 13. 锁扣垫片; |
| 7. 铁内护角;  | 14. 锁扣    |

- |  |  |
|--|--|
| 1. steel coil;                           | 8. iron external corner guard;         |
| 2. external peripheral rest-proof paper; | 9. external peripheral wrapping plate; |
| 3. inner core rest-proof paper;          | 10. inner peripheral guard plate;      |
| 4. paper inner corner guard;             | 11. circumferential banding strip;     |
| 5. paper external corner guard;          | 12. radial banding strip;              |
| 6. iron round cover;                     | 13. shim for lock;                     |
| 7. iron inner corner guard;              | 14. lock                               |

可提供钢卷和钢板产品，钢卷提供立式和卧式包装形式。  
 附有产品外标签和内标标签。  
 您需要的包装形式和标签要求，请联系我们确认。

Offers coils and sheets, coil packed in a vertical form or a horizontal.  
 A label that indicates the manufacturing history is affixed to the outside of the packaging. In addition, a service card is contained inside.  
 With regard to types of packing and markings, please consult us.

## 产品标准 Products Standard

### 1. 镀锡板 ETP

电镀锡板订货标准为Q/BQB450-2009, 此标准非等效采用了JIS G 3303:2008、DIN EN 10202:2001、EN 10203。

ETP orders are placed with Baosteel in accordance with Q/BQB 450-2009 standard which uses in a non-equivalent to JIS G 3303:2008, DIN EN 10202:2001, EN 10203 standards.

### 2. 镀铬板 TFS

电镀铬板订货标准为Q/BQB455-2009, 此标准非等效采用了JIS G 3315:2008、DIN EN 10202:2001、EN 10203。

TFS orders are placed with Baosteel in accordance with Q/BQB 455-2009 standard which uses in a non-equivalent to JIS G 3315:2008, DIN EN 10202:2001, EN 10203 standards.



## 常用规格表

### List of Usual Specification

	调质度 Temper	公称厚度 Nominal Thickness (mm)	公称宽度 Nominal Width (mm)
SR-CA 材	T-1.5CA	0.22-0.25	700-840
		0.26-0.35	700-915
		0.36-0.49	790-960
	T-2.5CA	0.22	700-880
		0.23-0.26	700-1050
		0.27-0.45	700-1150
		0.46-0.55	900-1150
	T-3CA	0.18-0.19	700-840
		0.20-0.21	700-880
		0.22	700-940
		0.23-0.26	700-1050
		0.27-0.35	700-1150
		0.36-0.45	800-1150
		0.46-0.55	900-1150
	T-3.5CA	0.20-0.22	700-900
		0.23-0.32	700-1050
		0.33-0.50	800-1050
	T-4CA	0.18-0.22	700-1050
		0.23-0.26	700-1150
		0.27-0.36	700-1080
	T-5CA	0.18-0.22	700-1050
		0.23-0.26	700-1150
		0.27-0.29	700-960
0.30-0.50		800-1000	
	T-2.5CA,T-3CA (IF 钢)	0.26-0.5	800-1000

注：  
具体的可供规格以现场实际生产为准。

Note:  
Specific specifications are available on-site subject to the actual production.

Available Specifications and Sizes  
供货规格

	调质度 Temper	公称厚度 Nominal Thickness (mm)	公称宽度 Nominal Width (mm)
SR-BA 材	T-2BA	0.22-0.50	700-960
	T-2.5BA,T-3BA	0.19	700-860
		0.20	700-900
		0.21	700-920
		0.22-0.23	700-940
		0.24-0.50	700-960
DR-CA 材	DR520 DR7M	0.15	700-880
		0.16	700-920
		0.17	700-940
		0.18-0.28	700-970
		0.29-0.40	800-970
	DR550 DR8	0.14	700-880
		0.15-0.16	700-920
		0.17-0.26	700-970
		0.27-0.38	800-970
	DR580 DR8M	0.14	700-920
		0.15	700-950
		0.16-0.25	700-970
		0.26-0.36	800-1000
	DR620 DR9	0.14	700-940
		0.15-0.23	700-970
		0.24-0.34	800-1000
DR-BA 材	DR520 DR7M	0.15	700-880
		0.16-0.17	700-900
		0.18-0.40	700-960
	DR550 DR8	0.14	700-820
		0.15	700-900
		0.16	700-920
		0.17-0.37	700-960





# Usage Precautions

## 使用须知

### 镀锡板使用注意事项

#### Usage Precautions for ETP

1. 由于镀锡板的镀层为较软的金属锡，应采取适当保护措施，以避免运输途中的擦划伤。
  2. 由于镀锡板的耐蚀性、涂装性、焊接性和力学性能具有时效性，会随着时间流逝变化，所以请在收货后尽快使用。
  3. 尽管镀锡板具有出色的耐腐蚀性，但在潮湿环境下仍可能发生锈蚀，所以请在开包后尽快使用。
  4. 由于锡可溶于强碱性溶剂，因此镀锡板用于包装碱性内容物时，需要对内表面进行涂装。
  5. 含有硫化物质的内容物会导致镀锡板表面发黑，需要对内表面进行涂装。
- 
1. As ETP is covered by soft metallic tin coatings, due precautions should be taken not to cause scratches by rough handling or vibration during transportation.
  2. Paintability, printability, solderability, and mechanical properties of ETP tend to deteriorate as time elapses after production. Use as soon as possible after delivery.
  3. Although ETP has excellent corrosion resistance, it tends to rust in a humid atmosphere. Use as soon as possible after unpacking.
  4. Tin is dissolved by a strongly alkaline solution. When using ETP for making cans for alkaline contents, paint the internal surface.
  5. As contents that contain sulfur cause blackening of the ETP surface, paint the internal surface.

### 镀铬板使用注意事项

#### Usage Precautions for TFS

1. 镀铬板不适用于钎焊和拉拔成形；涂装后的镀铬板几乎等同于镀锡板。
2. 镀铬板的金属镀层具有很高的电阻，焊接时应事先去除焊点区域的金属镀层。
3. 镀铬板在潮湿环境下会发生锈蚀，所以请在开包后尽快使用。
4. 使用镀铬板制作的罐头外表面应进行涂装，以防止锈蚀；内表面也应进行涂装，除非内容物为机油或食用油。
5. 镀铬板不具备镀锡板所具有的阳极保护作用。应采取适当保护措施，以避免使用镀铬板在制成罐头并涂饰之后表面出现擦划伤。

1. TFS is not compatible with soldering and DI forming. However, once painted, it can be used in almost all applications where TIN PLATE is used.
2. The metallic coating layer of TFS has a high electrical resistance. When welding it, the metallic coating layers in the welded areas should be removed in advance.
3. TFS tends to rust in a humid atmosphere. Use as soon as possible after unpacking.
4. The external surfaces of cans should be painted to prevent corrosion. The internal surfaces should also be painted to prevent corrosion except when the content is motor oil or cooking oil.
5. TFS does not provide sacrificial protection like TIN PLATE. Due precautions should be taken not to cause scratches on the surface of TFS after it is formed into cans and painted.



# Information Required with Orders and Inquiries

## 订货须知

订货时用户需提供下列信息

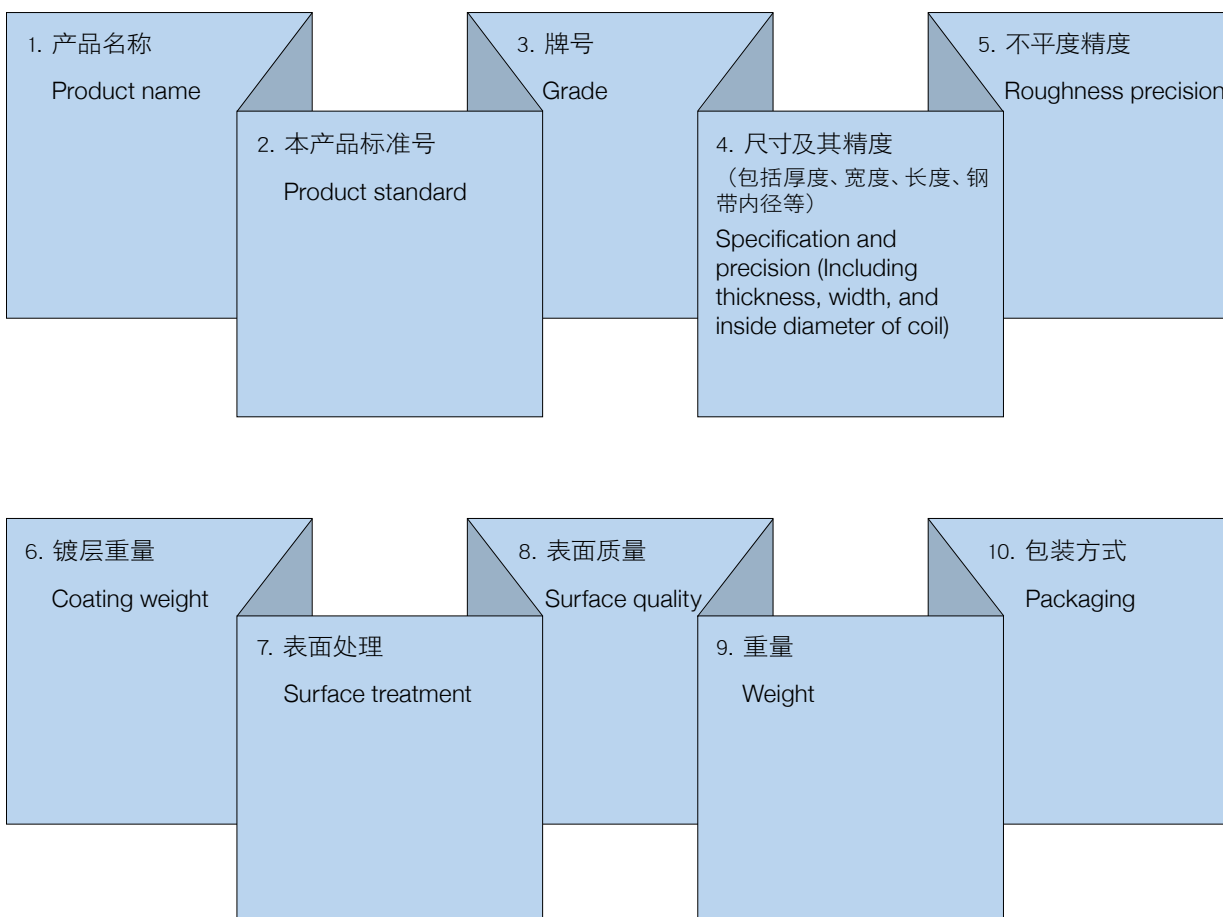

宝山钢铁股份有限公司  
http://www.baosteel.com

BAOSHAN IRON & STEEL CO., LTD.  
http://www.baosteel.com

**薄板销售部**

地址: 上海宝山同济路1800号  
邮编: 201900  
电话: 021-26641561  
传真: 021-26641560

**产品发展部**

地址: 上海宝山同济路1800号  
邮编: 201900  
电话: 021-26641824  
传真: 021-26645299

**宝钢服务热线**

**Baosteel Service Hot-line**

800-820-8590  
021-26648888

**宝钢在线**

http://www.baosteel.net.cn

**国内贸易公司**

上海宝钢钢材贸易有限公司  
电话: 021-50509696  
传真: 021-68404618

广州宝钢南方贸易有限公司  
电话: 020-32219999  
传真: 020-32219555

天津宝钢北方贸易有限公司  
电话: 022-84905800  
传真: 022-84905806

成都宝钢西部贸易有限公司  
电话: 028-85335388  
传真: 028-85335680

武汉宝钢华中贸易有限公司  
电话: 027-84298800  
传真: 027-84298224

上海宝钢商贸有限公司  
电话: 021-56121212  
传真: 021-56126584

上海宝钢浦东国际贸易有限公司  
电话: 021-36014655  
传真: 021-51266522 51266533

上海宝钢宝山钢材贸易有限公司  
电话: 021-36014688  
传真: 021-51266500

**亚澳地区 Asia and Australia**

宝和通商株式会社  
**HOWA TRADING CO., LTD.**  
TEL: 0081-3-3237-9121  
FAX: 0081-3-3237-9203

宝和通商首尔事务所  
**HOWA TRADING CO., LTD., SEOUL OFFICE**  
TEL: 0082-2-5080893  
FAX: 0082-2-5080891

宝钢澳大利亚贸易有限公司  
**BAO AUSTRALIA PTY LTD**  
TEL: 0061-8-94810535  
FAX: 0061-8-94810536

宝钢新加坡贸易有限公司  
**BAOSTEEL SINGAPOPE PTE LTD.**  
TEL: 0065-63336818  
FAX: 0065-63336819

越南代表处  
**VIETNAM REPRESENTATIVE OFFICE**  
TEL: 0084-8-9100126  
FAX: 0084-8-9100124

泰国代表处  
**THAILAND REPRESENTATIVE OFFICE**  
TEL: 0066-2-6543008  
FAX: 0066-2-6543010

**欧非地区 Europe and Africa**

宝钢欧洲贸易有限公司  
**BAOSTEEL TRADING EUROPE GMBH**  
TEL: 0049-40-419940  
FAX: 0049-40-41994130

宝钢西班牙有限公司  
**BAOSTEEL ESPAÑA, S.L.**  
TEL: 0034-93-4119325  
FAX: 0034-93-4119330

中东代表处  
**BAOSTEEL MIDDLE EAST REPRESENTATIVE OFFICE**  
TEL: 00971-4-8810788  
FAX: 00971-4-8810789

宝钢意大利钢材集散中心有限公司  
**BAOSTEEL ITALIA DISTRIBUTION CENTER SPA**  
TEL: 0039-010-5308872  
FAX: 0039-010-5308874

**美洲地区 America**

宝钢美洲有限公司  
**BAOSTEEL AMERICA INC.**  
TEL: 001-201-4571144  
FAX: 001-201-4570909

底特律代表处  
**DETROIT REPRESENTATIVE OFFICE**  
TEL: 001-248-3516230  
FAX: 001-248-3516231

休斯顿代表处  
**HOUSTON REPRESENTATIVE OFFICE**  
TEL: 001-281-4847333  
FAX: 001-281-4842655

洛杉矶代表处  
**LOS ANGELES REPRESENTATIVE OFFICE**  
TEL: 001-949-7526789  
FAX: 001-949-7521234

加拿大代表处  
**CANADA REPRESENTATIVE OFFICE**  
TEL: 001-905-2721956  
FAX: 001-905-2722407

里约代表处  
**BAOSTEEL DO BRAZIL LTDA.**  
TEL: 0055-21-25311363  
FAX: 0055-21-25310298